

hp Integrity cx2600 Site Preparation Guide

Regulatory Model Number: RSVLA-0303-DC

Version 3.0



**Manufacturing Part Number: cx2600_SitePrep
April 2004**

U.S.A.

© Copyright 2004 Hewlett-Packard Development Company, L.P..

Legal Notices

Copyright Notices. © Copyright 2004 Hewlett-Packard Development Company, L.P.

The information contained herein is subject to change without notice. The only warranties for HP products and services are set forth in the express warranty statements accompanying such products and services. Nothing herein should be construed as constituting an additional warranty. HP shall not be liable for technical or editorial errors or omissions contained herein.

Adobe and Acrobat are trademarks of Adobe Systems Incorporated. HP-UX Release 10.20 and later and HP-UX Release 11.00 and later (in both 32 and 64-bit configurations) on all HP 9000 computers are Open Group UNIX 95 branded products. Intel and Itanium are trademarks or registered trademarks of Intel Corporation or its subsidiaries in the United States and other countries. Linux is a registered trademark of Linus Torvalds. UNIX is a registered trademark of The Open Group. Windows is a registered trademark of Microsoft Corporation.

Printed in the U.S.A.

Reproduction, adaptation, or translation of this document without prior written permission is prohibited, except as allowed under the copyright laws.

Related Documents. The *HP Server Documentation CD-ROM* has been provided with your server. It contains a complete documentation set for the server, including localized versions of key documents. Included on the CD-ROM are the *Site Preparation* and *Operations* guides, which contain in-depth troubleshooting, installation, and repair information.

The CD will autorun when you insert it into a Windows® workstation, or, point your browser at the index.htm file located under the **Start** directory of the CD. All users, including UNIX®/Linux, can access a complete manual set by viewing the directory **manuals**. The manuals are in Adobe® Acrobat® Reader (pdf) format.

IMPORTANT The latest versions of these documents, and any updates to these documents, are posted under the appropriate server at <http://docs.hp.com>.

Where to Get Help. For online access to technical support information, self-solve tools, online assistance, community forums of IT experts, broad multivendor knowledge base, and monitoring and diagnostic tools, go to <http://www.hp.com/support>.

1. About This Document

What's in This Document	7
Typographical Conventions	7
Related Documents	7
HP Encourages Your Comments	8
Where to Get Help	8
Information to Collect Before You Contact Support	8

2. System Specifications

System Configuration	11
Dimensions and Weights	13
Electrical Specifications	14
Grounding	14
Disconnect Device and Branch Circuit Protection	14
System Power Specifications	15
Environmental Specifications	16
Temperature and Humidity	16
Operating Environment	16
Environmental Temperature Sensor	16
Nonoperating Environment	16
Cooling	17
Acoustic Noise Specification	19

3. General Site Preparation Guidelines

Electrical Factors	21
Computer Room Safety	21
Power Consumption	22
Electrical Load Requirements (Circuit Breaker Sizing)	22
Power Quality	22
Distribution Hardware	23
Grounding Systems	24
System Installation Guidelines	26
Environmental Elements	28
Computer Room Preparation	28
Cooling Requirements	28
Humidity Level	30
Dust and Pollution Control	30
Metallic Particulate Contamination	31
Electrostatic Discharge (ESD) Prevention	32
Acoustics	32
Facility Characteristics	33
Floor Loading	33
Windows	35
Space Requirements	36
Delivery Space Requirements	36
Operational Space Requirements	36

Contents

Floor Plan Grid	36
Conversion Factors and Formulas	37
Conversion Factors	37
Formulas	37
Sample of an Installation Schedule	38
Sample Site Inspection Checklist	39
Delivery Survey	42
Glossary	45
Index	47

Figure 2-1. hp Integrity cx2600 Server	12
Figure 2-2. Chassis Ground Lug	14
Figure 2-3. Airflow Through hp Integrity cx2600 Server	17
Figure 3-1. Raised Floor Metal Strip Ground System	26
Figure 3-2. Delivery Survey (Part 1)	43
Figure 3-3. Delivery Survey (Part 2)	44

1 About This Document

This document describes how to prepare your site for installation of your hp Integrity cx2600 Server, Regulatory Model Number: RSVLA-0303-DC.

The document printing date and part number indicate the document's current edition. The printing date will change when a new edition is printed. Minor changes may be made at reprint without changing the printing date. The document part number will change when extensive changes are made.

Document updates may be issued between editions to correct errors or document product changes. To ensure that you receive the updated or new editions, you should subscribe to the appropriate product support service. See your HP sales representative for details.

IMPORTANT The latest version of this document can be found online at <http://docs.hp.com>.

What's in This Document

The *hp Integrity cx2600 Site Preparation Guide* contains these chapters:

- **Chapter 2, "System Specifications."** Use this chapter to learn about your system's weight, dimensions, electrical, and environmental specifications.
- **Chapter 3, "General Site Preparation Guidelines."** Use this chapter to prepare your computer room facility to accept your hp Integrity cx2600 Server.

Typographical Conventions

This document uses the following conventions.

<i>Title</i>	The title of a document or a CD.
KeyCap	The name of a keyboard key. Note that Return and Enter both refer to the same key.
<i>Emphasis</i>	Text that is emphasized.
Bold	Text that is strongly emphasized, such as the summary text in bulleted paragraphs.
ComputerOut	Text displayed by the computer.
UserInput	Commands and other text that you type.
Command	A command name or qualified command phrase.

Related Documents

The *HP Server Documentation CD-ROM* has been provided with your server. It contains a complete documentation set for the server, including localized versions of key documents. Included on the CD-ROM are the *Site Preparation* and *Operations and Maintenance* guides, which contain in-depth troubleshooting, installation, and repair information.

The CD will autorun when you insert it into a Windows workstation, or, point your browser at the index.htm file located under the **Start** directory of the CD. All users, including UNIX/Linux, can access a complete manual set by viewing the directory **manuals**. The manuals are in Adobe Acrobat Reader (pdf) format.

IMPORTANT The latest version of this document can be found online at <http://docs.hp.com>.

HP Encourages Your Comments

HP encourages your comments concerning this document. We are truly committed to providing documentation that meets your needs.

Please send any comments by contacting us at <http://docs.hp.com/assistance/index.html>.

Please include document title, manufacturing part number, and any comment, error found, or suggestion for improvement you have concerning this document.

Where to Get Help

For online access to technical support information, self-solve tools, online assistance, community forums of IT experts, broad multivendor knowledge base, and monitoring and diagnostic tools, go to <http://www.hp.com/support>.

For the latest information on HP-UX patches, check the HP IT Resource Center at <http://itrc.hp.com>.

Information to Collect Before You Contact Support

Before you contact HP support, you should:

Step 1. Check information on troubleshooting and attempt to solve the problem. See the *hp Integrity cx2600 Operation and Maintenance Guide*.

- Note failure symptoms and error indications (LEDs and messages) by checking the SEL and FPL logs.
- Try to determine precisely what did or did not happen.

Step 2. Collect the following information:

- The model number of your server (for example, cx2600).
- The product number of your server. This can be found on the identification label, which is found at the front of the unit (typically A6837B A6838B, and so on).
- The serial number of your server. This can be found on the identification label.

Step 3. Become familiar with your system configuration:

- Are you using the LAN, RS232, or web interface to monitor the server?

- How many processors, DIMMs, and PCI cards have been installed?
- What versions of processor, memory, and PCI cards are used and where are they installed?
- What accessories are installed?

Step 4. Determine the following:

- Which firmware versions are in use?
- When did the problem start?
- Have recent changes been made to the system?
- Which operating system and version is in use?

2 System Specifications

System Configuration

The following table lists the minimum and maximum configurations for an hp Integrity cx2600 Server.

Table 2-1 Minimum/Maximum Configuration

System Name	Minimum	Maximum
CPU	1	2
Power Supplies ^a	1	2
Memory	1 GB (4 X 256 MByte DIMMs)	24 GB (12 X 2GByte DIMMs)
Optional Internal Disks	1 Hot Plug Disk Drive: 36 GB 15K Ultra 320 or 73 GB 15K HDD or 146 GB 10K HDD	3 Hot Plug Disk Drives: 36 GB 15K Ultra 320 or 73 GB 15K HDD or 146 GB 10K HDD
Optional Internal Media	01 DVD ROM or 1 CD-RW / DVD-ROM	1 DVD ROM, or 1 CD-RW/DVD-ROM
Optional I/O	0	4 64-bit, 133 MHz PCI slots holding any of the following: 4 port 100baseTX Ethernet LAN adapter

- a. The standard configuration of the hp Integrity cx2600 Server includes 2 power supplies. While only 1 power supply can be used to power the HP Server, N+1 redundancy requires that a second power supply be installed. In normal operations, both power supplies are in use at all times.

Figure 2-1 **hp Integrity cx2600 Server**

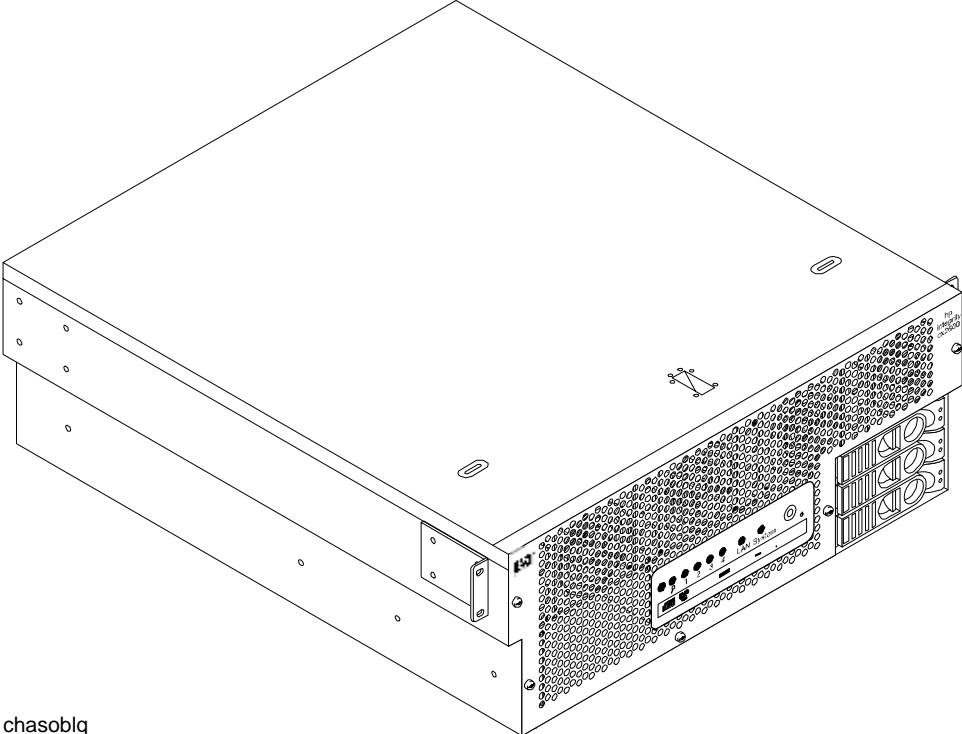

chasoblq

Dimensions and Weights

This section provides dimensions and weights of hp Integrity cx2600 Server and server components.

Table 2-2 hp Integrity cx2600 Server Dimensions and Weights

Dimension	Value
Height-inches (millimeters)	4U = 7 (178)
Width-inches (millimeters)	17.32 (440)
Depth-inches (millimeters)	20 (508)
Weight-pounds (kilograms)	Unloaded 62 (28.1) Fully loaded 70 (31.75)

Electrical Specifications

This section provides electrical specifications for the hp Integrity cx2600 Server.

Grounding

The site building shall provide a safety ground/protective earth ground to all cabinets. A chassis ground point is provided on the server rear panel. (See Figure 2-2.)

Figure 2-2 Chassis Ground Lug

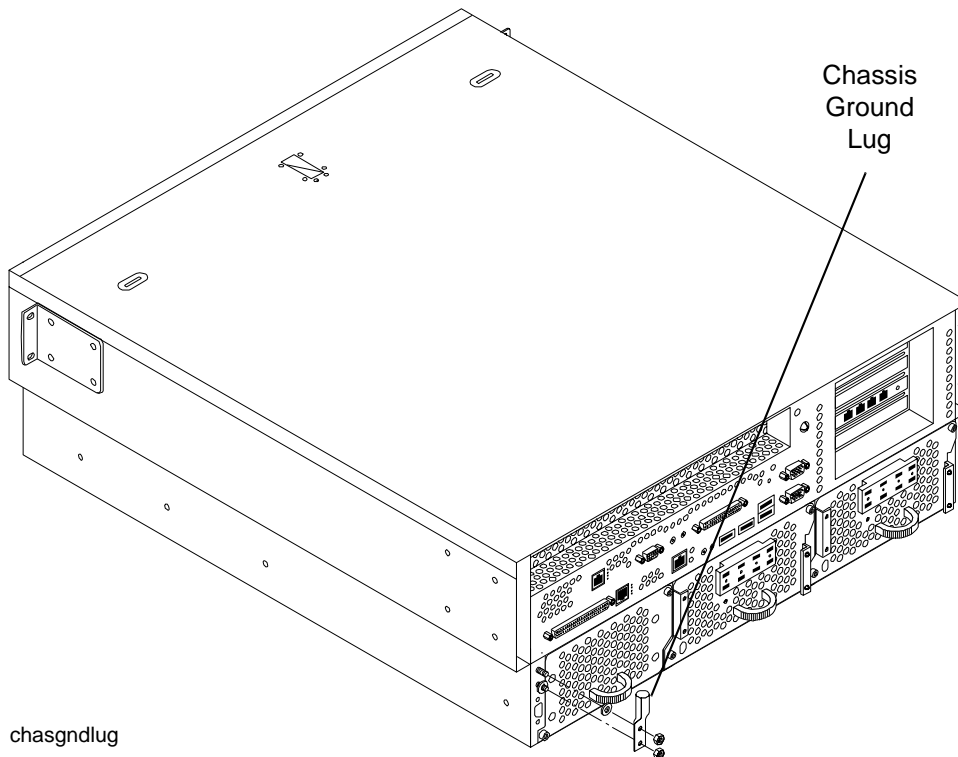

Install a PE (protective earthing) conductor that is identical in size, insulation material, and thickness to the branch-circuit supply conductors. The PE conductor must be green with yellow stripes. The earthing conductor is to be connected from the unit to the building installation earth or, if supplied by a separately derived system, at the supply transformer or motor-generator set grounding point.

Disconnect Device and Branch Circuit Protection

WARNING Failure to provide an appropriate disconnect device and branch circuit protection may endanger service personnel. Serious injury and equipment damage may result if this warning is not observed.

A suitable disconnect device must be provided as part of the building installation. The purpose of the disconnect device is to provide an easy and accessible means for removing power from the product for servicing.

A suitable branch circuit protection device must be provided as part of the building installation. The purpose of branch circuit protection is to limit current in the case of a fault.

The disconnect device may also provide branch circuit protection (for example, a circuit breaker). Alternately, separate disconnect and branch circuit protection devices (fuses and a disconnect switch) may be employed.

The devices must be rated based on the plate rating of the product in accordance with the applicable local codes and specific customer requirements. Branch circuit protection is commonly selected based on 125% of the product input rating. Such derating is to avoid nuisance tripping due to load surges or power transients and to meet code requirements. Applicable codes and customer requirements will vary.

System Power Specifications

Table 2-3 and Table 2-4 list the power specifications for the hp Integrity cx2600 Server. These tables provide information to help determine the amount of power needed for your computer room.

Table 2-3 System Power Specifications

Specification	Value
Nominal Input Voltage	-48VDC (-40 to -60 VDC)
Minimum Operating Voltage	-36 VDC
Maximum Operating Voltage	-72 VDC
Input Current	12A DC typical (with V_{IN} -48 VDC)
Input Power	580W typical (@ 85% efficiency)
Maximum Inrush Current	25 A
Maximum Output Current from each Power Supply	49A DC for the 12V output 3.5A DC for the V3.3sb output
Efficiency	82% (minimum)

Table 2-4 System Power Requirements

Power Required	Watts	Comments
Maximum configuration ^a	650	Maximum Theoretical
Typical configuration	580	

a. Maximum power is the sum of the worst case power consumption values of every subsystem in your hp Integrity cx2600 Server. These worst case values should be used to calculate the worst case power consumption for your facility installation.

Environmental Specifications

This section provides the temperature/humidity requirements, noise emission, and air flow specifications for the hp Integrity cx2600 Server.

Temperature and Humidity

Ambient intake air temperature is often different from ambient room temperature; you should measure the operating temperature and humidity directly in front of the cabinet cooling air intakes rather than just checking ambient room conditions.

Operating Environment

The system is designed to run continuously and meet reliability goals in an ambient temperature of 5°C –40°C at sea level. The maximum allowable temperature is derated 1°C per 1,000 feet of elevation above 5,000 feet above sea level up to 30°C at 10,000 feet. For optimum reliability and performance, the recommended operating range is 20°C to 25°C and 40%-50% relative humidity.

Environmental Temperature Sensor

To ensure that the system is operating within the published limits, the ambient operation temperature is measured using a sensor placed on the front panel LED status board. Data from the sensor is used to control the fan speed and also to initiate system overtemp shutdown.

Nonoperating Environment

The system is designed to withstand ambient temperatures between –40°C to 70°C under nonoperating conditions.

Cooling

Figure 2-3 Airflow Through hp Integrity cx2600 Server

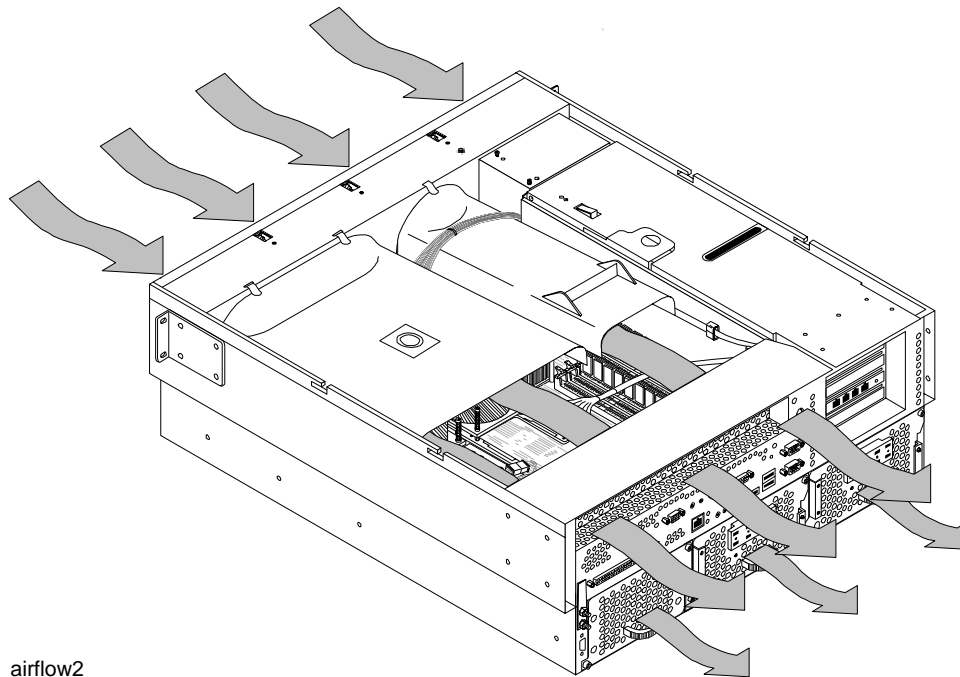

Overall System Cooling

The cabinet incorporates front to back airflow across the entire chassis. Four 80 mm, dual blade fans, mounted vertically in the front of the chassis, push air through the CPU, memory, and PCI sections. One 80 mm, dual blade fan and the internal power supply fans cool the lower section of the chassis.

The five 80 mm fans are controlled by circuits of the fan control board. The fan control circuits receive fan input from the BMC on the system board, and return fan status information. The fan circuit generate power and the pulse-width-modulated control signals to the fans and monitor the speed indicator signals from each of the fans. Fan failures are reported via the front panel diagnostic LEDs and in error messages. Room ambient air temperature is sensed on the front panel LED status board and provided to the system board.

CPU/Memory Cooling

Cooling for the processors (CPUs) and memory is provided by three 80 mm fans mounted in the front of the server chassis (fans 2, 3, and 4). Fan 2 is controlled by room ambient air temperature and provides air through the memory section of the chassis. Fans 3 and 4 are controlled by room ambient air temperature and processor (CPU) temperature. These two fans direct airflow across processor 1 (fan 4) and 2 (fan 3).

Power Supply Cooling

Cooling for the power supplies is provided by the 60 mm fans mounted in each of the power supply assemblies. Air is pushed through the power supply by the 60 mm fans and exhausted out the rear of the chassis.

PCI/Mass Storage Section Cooling

One 80 mm, dual blade fan pushes airflow through the PCI card cage. The fan is controlled by the room ambient temperature and runs at the speed necessary to maintain proper internal temperature throughout the PCI card cage.

Typical Power Dissipation and Cooling

The system configurations shown in Table 2-5 are typical of most systems and show the power and cooling values required for the listed components. These power and cooling values are considered typical and not maximum for the configurations shown.

Table 2-5 Typical Configuration Power Consumption Values

CPU	Memory	PCI Cards (assuming 10W each)	Hard Disk Drives	Typical Power	Typical Cooling
Qty	Gigabytes	Qty	Qty	Watts	BTU/Hr
1	1 GB (4 DIMMs @ 256 MB ea.)	1	1	360	1144
1	24 GB (12 DIMMs @ 2 GB ea.)	2	1	385	1212
2	24 GB (12 DIMMs @ 2 GB ea.)	3	2	575	1809
2	24 GB (12 DIMMs @ 2 GB ea.)	4	2	596	1876
2	24 GB (12 DIMMs @ 2 GB ea.)	1	2	531	1673
2	24 GB (12 DIMMs @ 2 GB ea.)	2	3	574	1809
2	24 GB (12 DIMMs @ 2 GB ea.)	3	3	596	1876
2	24 GB (12 DIMMs @ 2 GB ea.)	4	3	617	1944

Acoustic Noise Specification

The acoustic noise specification for the HP Server is as follows:

- 55 db LpA (sound pressure level at bystander position in a dedicated computer room environment temperature of <25°C).

3 General Site Preparation Guidelines

The following information provides general principles and practices to consider before the installation or operation of an hp Integrity cx2600 Server.

Electrical Factors

NOTE Electrical practices and suggestions in this guide are based on North American practices. For regions and areas outside North America, local electrical codes will take precedence over North American electrical codes.

An example would be the recommendation that the PE (Protective Earthing) conductor be green with yellow stripes. This requirement is a North American directive and does not override the local code requirements for a region or area outside North America.

Local Authority Has Jurisdiction (LAHJ) and should make the final decision regarding adherence to region-specific or area-specific electrical codes and guidelines. The LAHJ acronym is used throughout the section to denote that local authority has jurisdiction.

Proper design and installation of a power distribution system requires specialized skills. Those responsible for this task must have a thorough knowledge and understanding of appropriate electrical codes and the limitations of the power systems for computer and data processing equipment.

In general, a well-designed power distribution system exceeds the requirements of most electrical codes. A good design, when coupled with proper installation practices, produces the most trouble-free operation.

A detailed discussion of power distribution system design and installation is beyond the scope of this information. However, electrical factors relating to power distribution system design and installation must be considered during the site preparation process.

The electrical factors discussed in this section are:

- Computer room safety
- Power consumption
- Electrical load requirements (circuit breaker sizing)
- Power quality
- Distribution hardware
- System installation guidelines

Computer Room Safety

Inside the computer room, fire protection and adequate lighting (for equipment servicing) are important safety considerations. Federal and local safety codes govern computer installations.

Fire Protection

The National Fire Protection Association's Standard for the Protection of Electronic Computer Data Processing Equipment, NFPA 75, contains information on safety monitoring equipment for computer rooms.

Electrical Factors

Most computer room installations are equipped with the following fire protection devices:

- Smoke detectors
- Fire and temperature alarms
- Fire extinguishing system

Additional safety devices are:

- Circuit breakers
- An emergency power cutoff switch
- Devices specific to the geographic location for example, earthquake protection

Lighting Requirements for Equipment Servicing

Adequate lighting and utility outlets in a computer room reduce the possibility of accidents during equipment servicing. Safer servicing is also more efficient and, therefore, less costly.

For example, adequate lighting reduces the chances of connector damage when cables are installed or removed.

The minimum recommended illumination level is 70 foot-candles (756 lumens per square meter) when the light level is measured at 30 inches (76.2 cm) above the floor.

Working Space for Server Access

The recommended working space for performing maintenance on the server is three feet. The work space shall permit at least a 90° opening of equipment doors or hinged panels. When planning for the working space area, consider whether access to the server will be at the front, side, or rear of the server.

Power Consumption

When determining power requirements, you must consider any peripheral equipment that will be installed during initial installation or as a later update. Refer to the applicable documentation for such devices to determine the power required to support these devices.

Electrical Load Requirements (Circuit Breaker Sizing)

NOTE Local Authority Has Jurisdiction (LAHJ) and should make the final decision regarding adherence to country-specific electrical codes and guidelines.

It is good practice to derate power distribution systems for one or more of the following reasons:

- To avoid nuisance tripping from load shifts or power transients, circuit protection devices should never be run above 80% of their current ratings.
- Safety agencies derate most power connectors to 80% of their current ratings.

Power Quality

The intended source voltage for Telco systems is -48 VDC. The hp Integrity cx2600 Server is designed to operate over the range of -40 to -60 volts DC nominal. The server utilizes a DC to DC power supply to provide stable operation with a uniform internal voltage.

Sources of Voltage Fluctuations

Voltage fluctuations, sometimes called glitches, affect the quality of electrical power. Common sources of these disturbances are:

- Fluctuations occurring within the facility's distribution system
- Utility service low-voltage conditions (such as sags or brownouts)
- Wide and rapid variations in input voltage levels
- Electrical storms
- Faults in the distribution system wiring (such as loose connections)

Power System Protection

The hp Integrity cx2600 Server can be protected from the sources of many of these electrical disturbances by using:

- A dedicated power distribution system
- Power conditioning equipment
- Over- and under-voltage detection and protection circuits
- Screening to cancel out the effects of undesirable transmissions
- Lightning arresters on power cables to protect equipment against electrical storms

Precautions have been taken during power distribution system design to provide immunity to brief power outages. However, testing cannot conclusively rule out loss of service. Therefore, adherence to the following guidelines provides the best possible performance of power distribution systems for HP computer equipment:

- Dedicated power source—Isolates an hp Integrity cx2600 Server power distribution system from other circuits in the facility.
- Low-voltage detectors—Shuts equipment down automatically when a severe power disruption occurs. For peripheral equipment, these devices are recommended but optional.

Distribution Hardware

This section describes wire selection and the types of raceways (electrical conduits) used in the distribution system.

Wire Selection

Use copper conductors instead of aluminum, because aluminum's coefficient of expansion differs significantly from that of other metals used in power hardware. Because of this difference, aluminum conductors can cause connector hardware to work loose, overheat, and fail.

Raceway Systems (electrical conduits) (LAHJ)

Raceways (electrical conduits) form part of the protective ground path for personnel and equipment. Raceways protect the wiring from accidental damage and also provide a heatsink for the wires.

Any of the following types may be used:

- Electrical metallic tubing (EMT) thin-wall tubing
- Rigid (metal) conduit

Electrical Factors

- Liquidtight with RFI shield grounded (most commonly used under raised floors)

Building Distribution

All building feeders and branch circuitry should be in rigid metallic conduit with proper connectors (to provide ground continuity). Conduit that is exposed and subject to damage should be constructed of rigid galvanized steel.

Grounding Systems

Power Distribution Safety Grounding (LAHJ)

The power distribution safety grounding system consists of connecting various points in the power distribution system to earth ground using green (green/yellow) wire ground conductors. Having these ground connections tied to metal chassis parts that may be touched by computer room personnel protects them against shock hazard from current leakage and fault conditions.

Power distribution systems consist of several parts. HP recommends that these parts be solidly interconnected to provide an equipotential ground to all points.

Main Building Electrical Ground

The main electrical service entrance equipment should have an earth ground connection, as required by applicable codes. Connections such as a grounding rod, building steel, or a conductive type cold water service pipe provide an earth ground.

Electrical Conduit Ground

All electrical conduits should be made of rigid metallic conduit that is securely connected together or bonded to panels and electrical boxes, so as to provide a continuous grounding system.

Power Panel Ground

Each power panel should be grounded to the electrical service entrance with green (green/yellow) wire ground conductors. The green (green/yellow) wire ground conductors should be sized per applicable codes (based on circuit over current device ratings).

NOTE The green wire ground conductor mentioned above may be a black wire marked with green tape (LAHJ).

Computer Safety Ground

Ground all computer equipment with the green (green/yellow) wire included in the branch circuitry. The green (green/yellow) wire ground conductors should be connected to the appropriate power panel and should be sized per applicable codes (based on circuit over current device ratings).

A ground lug is provided on the chassis rear panel. Refer to “Grounding” on page 14.

Dual Power Source Grounding

When dual power sources are utilized, strong consideration should be given to measure voltage potentials. The use of dual power might create an electrical potential that can be hazardous to personnel and might cause performance issues for the equipment.

Dual power sources might originate from two separate DC sources. Voltage potentials from ground pin to ground pin of these sources should be measured and verified to be at or near 0.0 volts. Voltage levels that deviate or are measured above 3.0 volts should be further investigated. Increased voltages might be hazardous to personnel, and should be further investigated.

Cabinet Performance Grounding (High Frequency Ground)

Signal interconnects between system cabinets require high frequency ground return paths. Connect all cabinets to site ground.

NOTE In some cases power distribution system green (green/yellow) wire ground conductors are too long and inductive to provide adequate high frequency ground return paths. Therefore, a ground strap (customer-supplied) should be used for connecting the system cabinet to the site grounding grid (customer-supplied). When connecting this ground, ensure that the raised floor is properly grounded for high frequency.

Power panels located in close proximity to the computer equipment should also be connected to the site grounding grid. Methods of providing a sufficiently high frequency ground grid are described in the next sections.

Raised Floor High Frequency Noise Grounding

If a raised floor system is used, install a complete signal grounding grid for maintaining equal potential over a broad band of frequencies. The grounding grid should be connected to the equipment cabinet and electrical service entrance ground at multiple connection points using a minimum #6 AWG (16mm²) wire ground conductor. The following Figure 3-1 illustrates a metallic strip grounding system.

NOTE Regardless of the grounding connection method used, the raised floor should be grounded as an absolute safety minimum.

HP recommends the following approaches:

- **Excellent**—Add a grounding grid to the subfloor. The grounding grid should be made of copper strips mounted to the subfloor. The strips should be 0.032 in. (0.08 cm) thick and a minimum of 3.0 in. (8.0 cm) wide.
Connect each pedestal to four strips using 1/4 in. (6.0 mm) bolts tightened to the manufacturer's torque recommendation.
- **Better**—A grounded #6 AWG minimum copper wire grid mechanically clamped to floor pedestals and properly bonded to the building/site ground.
- **Good**—Use the raised floor structure as a ground grid. In this case, the floor must be designed as a ground grid with bolted down stringers and corrosion resistive plating (to provide low resistance and attachment points for connection to service entrance ground and HP computer equipment). The use of conductive floor tiles with this style of grid further enhances ground performance. The structure needs to be mechanically bonded to a known good ground point.

Figure 3-1 **Raised Floor Metal Strip Ground System**

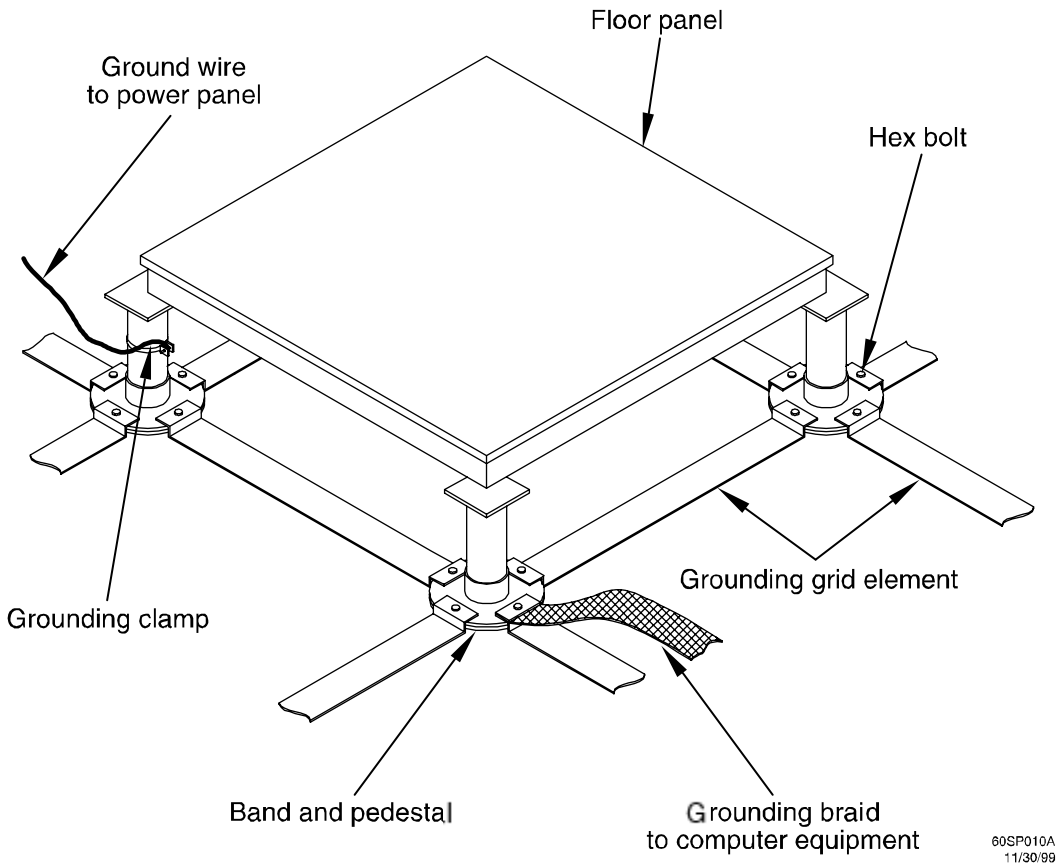

Equipment Grounding Implementation Details

Connect all HP equipment cabinets to the site ground grid as follows:

- Step 1.** Attach one end of each ground strap to the applicable cabinet ground lug.
- Step 2.** Attach the other end to the nearest pedestal base (raised floor) or cable trough ground point (nonraised floor).
- Step 3.** Check that the braid contact on each end of the ground strap consists of a terminal and connection hardware (a 1/4-in. [6.0-mm] bolt, nuts, and washers).
- Step 4.** Check that the braid contact connection points are free of paint or other insulating material and treated with a contact enhancement compound (similar to Burndy Penetrox).

System Installation Guidelines

This section contains information about installation practices. Some common pitfalls are highlighted. Both power cable and data communications cable installations are discussed.

NOTE In domestic installations, the proper receptacles should be installed prior to the arrival of Hewlett-Packard equipment. Refer to the appropriate installation guide for installation procedures.

Wiring Connections

Expansion and contraction rates vary among different metals. Therefore, the integrity of an electrical connection depends on the restraining force applied. Connections that are too tight compress or deform the hardware and cause it to weaken. This usually leads to high impedance, preventing circuit breakers from tripping when needed, or can contribute to a buildup of high frequency noise.

CAUTION Connections that are too loose or too tight can have a high impedance that causes serious problems, such as erratic equipment operation. A high impedance connection overheats and sometimes causes fire or high temperatures that can destroy hard-to-replace components such as distribution panels or system bus bars.

Wiring connections must be properly torqued. Many equipment manufacturers specify the proper connection torque values for their hardware.

Ground connections must only be made on a conductive, nonpainted surface. When equipment vibration is present, lock washers must be used on all connections to prevent connection hardware from working loose.

Data Communications Cables

Power transformers create high-energy fields in the form of electromagnetic interference (EMI). Heavy foot traffic can create electrostatic discharge (ESD) that can damage electronic components. Route data communications cables away from these areas. Use shielded data communications cables that meet approved industry standards to reduce the effects of external fields. These shielded communications cables must be grounded at both ends.

Environmental Elements

The following environmental elements can affect an hp Integrity cx2600 Server installation:

- Computer room preparation
- Cooling requirements
- Humidity level
- Air conditioning ducts
- Dust and pollution control
- Electrostatic discharge (ESD) prevention
- Acoustics (noise reduction)

Computer Room Preparation

The following guidelines are recommended when preparing a computer room for an hp Integrity cx2600 Server:

- Locate the computer room away from the exterior walls of the building to avoid the heat gain from windows and exterior wall surfaces.
- When exterior windows are unavoidable, use windows that are double- or triple-glazed and shaded to prevent direct sunlight from entering the computer room.
- Maintain the computer room at a positive pressure relative to surrounding spaces.
- Use a vapor barrier installed around the entire computer room envelope to restrain moisture migration.
- Caulk and vapor seal all pipes and cables that penetrate the envelope.
- Use at least a 12-inch raised floor system for minimum favorable room air distribution system (underfloor distribution).
- Ensure a minimum clearance of 12 inches between the top of the hp Integrity cx2600 Server cabinet and the ceiling to allow for return air flow and ensure that all ceiling tiles are in place.
- Allow 18 inches (or local code minimum clearance) from the top of the hp Integrity cx2600 Server cabinet to the fire sprinkler heads.

Cooling Requirements

Air conditioning equipment requirements and recommendations are described in the following sections.

Basic Air Conditioning Equipment Requirements

The cooling capacity of the installed air conditioning equipment for the computer room should be sufficient to offset the computer equipment dissipation loads, as well as any space envelope heat gain. This equipment should include:

- Air filtration
- Cooling or dehumidification
- Humidification

- Reheating
- Air distribution
- System controls adequate to maintain the computer room within specified operating ranges

Lighting and personnel must also be included. For example, a person dissipates about 450 BTUs per hour while performing a typical computer room task.

Air Conditioning System Guidelines

The following guidelines are recommended when designing an air conditioning system and selecting the necessary equipment:

- The air conditioning system that serves the computer room should be capable of operating 24 hours a day, 365 days a year. It should also be independent of other systems in the building.
- Consider the long-term value of hp Integrity cx2600 Server availability, redundant air conditioning equipment, or capacity.
- The system should be capable of handling any future hp Integrity cx2600 Server expansion.
- Air conditioning equipment air filters should have a minimum rating of 45% (based on ASHRAE Standard 52-76, Dust Spot Efficiency Test).
- Introduce only enough outside air into the system to meet building code requirements (for human occupancy) and to maintain a positive air pressure in the computer room.

Air Conditioning System Types

The following three air conditioning system types are listed in order of recommendation:

- Complete self-contained package unit(s) with remote condenser(s). These systems are available with up or down discharge and are usually located in the computer room.
- Chilled water package unit with remote chilled water plant. These systems are available with up or down discharge and are usually located in the computer room.
- Central station air handling units with remote refrigeration equipment. These systems are usually located outside the computer room.

Basic Air Distribution Systems

A basic air distribution system includes supply air and return air.

An air distribution system should be zoned to deliver an adequate amount of supply air to the cooling air intake vents of the hp Integrity cx2600 Server equipment cabinets. Supply air temperature should be maintained within the following parameters:

- Ceiling supply system—From 55°F (12.8°C) to 60°F (15.6°C)
- Floor supply system—At least 60°F (15.6°C)

If a ceiling plenum return air system or a ducted ceiling return air system is used, the return air grill(s) in the ceiling should be above the exhaust area or the exhaust row.

The following three types of air distribution system are listed in order of recommendation:

- Underfloor air distribution system—Downflow air conditioning equipment located on the raised floor of the computer room uses the cavity beneath the raised floor as a plenum for the supply air.

Return air from an underfloor air distribution system can be ducted return air (DRA) above the ceiling.

Environmental Elements

Perforated floor panels (available from the raised floor manufacturer) should be located around the front of the system cabinets. Supply air emitted through the perforated floor panels is then available near the cooling air intake vents of the hp Integrity cx2600 Server cabinets.

- Ceiling plenum air distribution system—Supply air is ducted into the ceiling plenum from upflow air conditioning equipment located in the computer room or from an air handling unit (remote).

The ceiling construction should resist air leakage. Place perforated ceiling panels (with down discharge air flow characteristics) around the front of the system cabinets. The supply air emitted downward from the perforated ceiling panels is then available near the cooling air intake vents of the hp Integrity cx2600 Server cabinets.

Return air should be ducted back to the air conditioning equipment through the return air duct above the ceiling.

- Above ceiling ducted air distribution system—Supply air is ducted into a ceiling diffuser system from upflow air conditioning equipment located in the computer room or from an air handling unit (remote).

Return air from an above ceiling ducted air distribution system may be ducted return air (DRA) above the ceiling, or ceiling plenum return air (CPRA).

Adjust the supply air diffuser system grilles to direct the cooling air downward around the front of the hp Integrity cx2600 Server cabinets. The supply air is then available near the cooling air intake vents of the hp Integrity cx2600 Server cabinets.

Air Conditioning System Installation

All air conditioning equipment, materials, and installation must comply with any applicable construction codes. Installation of the various components of the air conditioning system must also conform to the air conditioning equipment manufacturer's recommendations.

Air Conditioning Ducts

Use separate computer room air conditioning duct work. If it is not separate from the rest of the building, it might be difficult to control cooling and air pressure levels. Duct work seals are important for maintaining a balanced air conditioning system and high static air pressure. Adequate cooling capacity means little if the direction and rate of air flow cannot be controlled because of poor duct sealing. Also, the ducts should not be exposed to warm air, or humidity levels may increase.

Humidity Level

Maintain proper humidity levels at 40 to 55% RH. High humidity causes galvanic actions to occur between some dissimilar metals. This eventually causes a high resistance between connections, leading to equipment failures. High humidity can also have an adverse effect on some magnetic tapes and paper media.

CAUTION Low humidity contributes to undesirably high levels of electrostatic charges. This increases the electrostatic discharge (ESD) voltage potential. ESD can cause component damage during servicing operations. Paper feed problems on high-speed printers are usually encountered in low-humidity environments.

Low humidity levels are often the result of the facility heating system and occur during the cold season. Most heating systems cause air to have a low humidity level, unless the system has a built-in humidifier.

Dust and Pollution Control

Computer equipment can be adversely affected by dust and microscopic particles in the site environment.

Specifically, disk drives, tape drives, and some other mechanical devices can have bearing failures resulting from airborne abrasive particles. Dust may also blanket electronic components like printed circuit boards, causing premature failure due to excess heat and/or humidity build up on the boards. Other failures to power supplies and other electronic components can be caused by metallically conductive particles, including zinc whiskers. These metallic particles are conductive and can short circuit electronic components. Use every effort to ensure that the environment is as dust- and particulate-free as possible. See the following heading titled **Metallic Particulate Contamination** for additional details.

Smaller particles can pass through some filters, and over a period of time, cause problems in mechanical parts. Small dust particles can be prevented from entering the computer room by maintaining the air conditioning system at a high static air pressure level.

Other sources of dust, metallic, conductive, abrasive, and/or microscopic particles can be present. Some sources of these particulates are:

- Subfloor shedding
- Raised floor shedding
- Ceiling tile shedding

These particulates are not always visible to the naked eye. A good check to determine their possible presence is to check the underside of the tiles. The tile should be shiny, galvanized, and free from rust.

The computer room should be kept clean. The following guidelines are recommended:

- Smoking—Establish a no-smoking policy. Cigarette smoke particles are eight times larger than the clearance between disk drive read/write heads and the disk surface.
- Printer—Locate printers and paper products in a separate room to eliminate paper particulate problems.
- Eating or drinking—Establish a no-eating or drinking policy. Spilled liquids can cause short circuits in equipment such as keyboards.
- Tile floors—Use a dust-absorbent cloth mop rather than a dry mop to clean tile floors.

Special precautions are necessary if the computer room is near a source of air pollution. Some air pollutants, especially hydrogen sulfide (H₂S), are not only unpleasant but corrosive as well. Hydrogen sulfide damages wiring and delicate sound equipment. The use of activated charcoal filters reduces this form of air pollution.

Metallic Particulate Contamination

Metallic particulates can be especially harmful around electronic equipment. This type of contamination may enter the data center environment from a variety of sources, including but not limited to raised floor tiles, worn air conditioning parts, heating ducts, rotor brushes in vacuum cleaners, or printer component wear. Because metallic particulates conduct electricity, they have an increased potential for creating short circuits in electronic equipment. This problem is exaggerated by the increasingly dense circuitry of electronic equipment.

Over time, very fine whiskers of pure metal can form on electroplated zinc, cadmium, or tin surfaces. If these whiskers are disturbed, they may break off and become airborne, possibly causing failures or operational interruptions. For over 50 years, the electronics industry has been aware of the relatively rare but possible threat posed by metallic particulate contamination. During recent years, a growing concern has developed in computer rooms where these conductive contaminants are formed on the bottom of some raised floor tiles.

Although this problem is relatively rare, it may be an issue within your computer room. Since metallic contamination can cause permanent or intermittent failures on your electronic equipment, Hewlett-Packard strongly recommends that your site be evaluated for metallic particulate contamination before installation of electronic equipment.

Electrostatic Discharge (ESD) Prevention

Static charges (voltage levels) occur when objects are separated or rubbed together. The voltage level of a static charge is determined by the following factors:

- Types of materials
- Relative humidity
- Rate of change or separation

Table 3-1 Effect of Humidity on ESD Charge Levels

Personnel Activity ^a	Humidity ^b and Charge Levels (voltages) ^c			
	26%	32%	40%	50%
Person walking across a linoleum floor	6,150V	5,750V	4,625V	3,700V
Person walking across a carpeted floor	18,450V	17,250V	13,875V	11,100V
Person getting up from a plastic chair	24,600V	23,000V	18,500V	14,800V

- a. Source: B.A. Unger, *Electrostatic Discharge Failures of Semiconductor Devices* (Bell Laboratories, 1981).
- b. For the same relative humidity level, a high rate of airflow produces higher static charges than a low airflow rate.
- c. Some data in this table has been extrapolated.

Static Protection Measures

Follow these precautions to minimize possible ESD-induced failures in the computer room:

- Maintain recommended humidity level and airflow rates in the computer room.
- Install conductive flooring (conductive adhesive must be used when laying tiles).
- Use conductive wax if waxed floors are necessary.
- Ensure that all equipment and flooring are properly grounded and are at the same ground potential.
- Use conductive tables and chairs.
- Use a grounded wrist strap (or other grounding method) when handling circuit boards.
- Store spare electronic modules in antistatic containers.

Acoustics

Computer equipment and air conditioning blowers cause computer rooms to be noisy. Ambient noise level in a computer room can be reduced as follows:

- Dropped ceiling—Cover with a commercial grade of fire-resistant, acoustic rated, fiberglass ceiling tile.
- Sound deadening—Cover the walls with curtains or other sound deadening material.
- Removable partitions—Use foam rubber models for most effectiveness.

Facility Characteristics

This section contains information about facility characteristics that must be considered for the installation or operation of an hp Integrity cx2600 Server. Facility characteristics are:

- Floor loading
- Windows
- Altitude effects

Floor Loading

The computer room floor must be able to support the total weight of the installed hp Integrity cx2600 Servers as well as the weight of the individual cabinets as they are moved into position.

Floor loading is usually not an issue in nonraised floor installations. The information presented in this section is directed toward raised floor installations.

NOTE An appropriate floor system consultant should verify any floor system under consideration for an hp Integrity cx2600 Server installation.

Raised Floor Loading

Raised floor loading is a function of the manufacturer's load specification and the positioning of the equipment relative to the raised floor grid. While Hewlett-Packard cannot assume responsibility for determining the suitability of a particular raised floor system, it does provide information and illustrations for the customer or local agencies to determine installation requirements.

The following guidelines are recommended:

- Because many raised floor systems do not have grid stringers between floor stands, the lateral support for the floor stands depends on adjacent panels being in place. To avoid compromising this type of floor system while gaining under-floor access, remove only one floor panel at a time.
- Larger floor grids (bigger panels) are generally rated for lighter loads.

CAUTION Do not position or install any equipment cabinets on the raised floor system until you have carefully examined it to verify that it is adequate to support the appropriate installation.

Floor Loading Terms

Table 3-2 Floor Loading Term Definitions

Term	Definition
Dead load	The weight of the raised panel floor system, including the understructure. Expressed in lb/ft ² (kg/m ²).
Live load	The load that the floor system can safely support. Expressed in lb/ft ² (kg/m ²).
Concentrated load	The load that a floor panel can support on a 1-in. ² (6.45 cm ²) area at the panel's weakest point (typically the center of the panel), without the surface of the panel deflecting more than a predetermined amount.
Ultimate load	The maximum load (per floor panel) that the floor system can support without failure. Failure expressed by floor panel(s) breaking or bending. Ultimate load is usually stated as load per floor panel.
Rolling load	The load a floor panel can support (without failure) when a wheel of specified diameter and width is rolled across the panel.
Average floor load	Computed by dividing total equipment weight by the area of its footprint. This value is expressed in lb/ft ² (kg/m ²).

Average Floor Loading

The average floor load value is not appropriate for addressing raised floor ratings at the floor grid spacing level. However, it is useful for determining floor loading at the building level, such as the area of solid floor or span of raised floor tiles covered by the hp Integrity cx2600 Server footprint.

Typical Raised Floor Site

This section contains an example of a computer room raised floor system that is satisfactory for the installation of an hp Integrity cx2600 Server.

Based on specific information provided by HP, Tate Access Floors has approved its Series 800 all-steel access floor with bolt-together stringers and 24 in. (61.0 cm) by 24 in. (61.0 cm) floor panels.

In the event that the flooring is being replaced or a new floor is being installed, Tate Access Floors recommends its Series 1250 all-steel access floor with bolt-together stringers and 24 in. (61.0 cm) by 24 in. (61.0 cm) floor panels be used to support the HP installation.

NOTE If the specific floor being evaluated or considered is other than a Tate Series 800 floor, the specific floor manufacturer must be contacted to evaluate the floor being used.

The following table lists specifications for the Tate Access Floors Series 800 raised floor system.

Table 3-3 Typical Raised Floor Specifications

Item ^a	Rating
Dead load	7 lb/ft ² (34.2 kg/m ²)
Live load	313 lb/ft ² (1528.3 kg/m ²)

Table 3-3 Typical Raised Floor Specifications (Continued)

Item ^a	Rating
Concentrated load ^b	1250 lb (567 kg)
Ultimate load	4,000 lb (1814 kg) per panel
Rolling load	400 lb (181 kg)
Average floor load	500 lb (227 kg)

a. From Table 3-2 on page 34.

b. With 0.08 in. (0.2 cm) of span maximum deflection.

Windows

Avoid housing computers in a room with windows. Sunlight entering a computer room may cause problems. Magnetic tape storage media is damaged if exposed to direct sunlight. Also, the heat generated by sunlight places an additional load on the cooling system.

Space Requirements

This section contains information about space requirements for an hp Integrity cx2600 Server. This data should be used as the basic guideline for space plan developments. Other factors, such as airflow, lighting, and equipment space requirements must also be considered.

Delivery Space Requirements

There should be enough clearance to move equipment safely from the receiving area to the computer room. Permanent obstructions, such as pillars or narrow doorways, can cause equipment damage.

Delivery plans should include the possible removal of walls or doors.

Operational Space Requirements

Other factors must be considered along with the basic equipment dimensions. Reduced airflow around equipment causes overheating, which can lead to equipment failure. Therefore, the location and orientation of air conditioning ducts, as well as airflow direction, are important. Obstructions to equipment intake or exhaust airflow must be eliminated.

The locations of lighting fixtures and utility outlets affect servicing operations. Plan equipment layout to take advantage of lighting and utility outlets. Include clearance for opening and closing equipment doors.

Space planning should also include the possible addition of equipment or other changes in space requirements. Equipment layout plans should also include provisions for the following:

- Channels or fixtures used for routing data cables and power cables
- Access to air conditioning ducts, filters, lighting, and electrical power hardware
- Power conditioning equipment
- Cabinets for cleaning materials
- Maintenance area and spare parts

Floor Plan Grid

A floor plan grid is used to plan the location of equipment in the computer room. In addition to its use for planning, the floor plan grid should also be used when planning the locations of the following items:

- Air conditioning vents
- Lighting fixtures
- Utility outlets
- Doors
- Access areas for power wiring and air conditioning filters
- Equipment cable routing

Conversion Factors and Formulas

The conversion factors provided here are intended to ease data calculation for systems that do not conform specifically to the configurations listed in this *Site Preparation Guide*. Listed below are the conversion factors used in this document, as well as additional conversion factors which may be helpful in determining those factors required for site planning.

Conversion Factors

- Refrigeration
 - 1 watt = .86 kcal/h
 - 1 watt = 3.412 Btu/h
 - 1 watt = 2.843×10^{-4} tons
 - 1 ton = 200 Btu/min.
 - 1 ton = 12,000 Btu/h
 - 1 ton = 3,517.2W
- Metric Equivalents
 - 1 centimeter = 0.3937 in.
 - 1 meter = 3.28 ft
 - 1 meter = 1.09 yds
 - 1 in. = 2.54 cm
 - 1 ft = 0.305m
 - 1 CFM = 1.7 m³/h
- kVA Conversions
 - Three phase
 - $kVA = V \times A \times \sqrt{3} / 1000$
- Single phase
 - $kVA = V \times A / 1000$

Formulas

- $kVA = \text{Voltage} \times \text{Current (amps)}$
- $\text{Watts} = VA \times PF$
- $BTU = \text{Watts} \times 3.41$

Sample of an Installation Schedule

The following schedule is a general guideline for events for a large system installation. The final schedule will accommodate local requirements.

- 60 days before installation
 - Floor plan design completed and mailed to Hewlett-Packard (if required to be an HP task)
- 30 days before installation
 - Primary power and air conditioning installation completed
 - Telephone and data cables installed
 - Fire protection equipment installed
 - Major facility changes completed
 - Special delivery requirements defined
 - Site inspection survey completed
 - Delivery survey completed
 - A signed copy of the site inspection and delivery survey mailed to Hewlett-Packard
 - Site inspection and predelivery coordination meeting arranged with a Hewlett-Packard representative to review the inspection checklist and arrange an installation schedule.
- 7 days before installation
 - Final check made with a Hewlett-Packard site preparation specialist to resolve any last minute problems

NOTE Not all installations follow a schedule like the one noted above. Sometimes, an hp Integrity cx2600 Server is purchased through another vendor, which can preclude a rigid schedule. Other conditions could also prevent following this schedule. For those situations, consider a milestone schedule.

- Site Preparation—schedule with the customer as soon as possible after the order is placed.
 - Site Verification—schedule with the customer a minimum of one to two days before the hp Integrity cx2600 Server is scheduled to be installed.
-

Sample Site Inspection Checklist

Table 3-4 Customer and Hewlett-Packard Information

Customer Information	
Name:	Phone No:
Street Address:	City or Town
State or Province:	Country:
Zip or postal code:	
Primary customer contact:	Phone No.:
Secondary customer contact:	Phone No.:
Traffic coordinator:	Phone No.:
Hewlett-Packard information	
Sales representative:	Order No:
Representative making survey:	Date:
Scheduled delivery date:	

Table 3-5 Site Inspection Checklist

Please check either Yes or No. If No, include comment# or date				Comment or Date
Computer room				
No.	Area or condition	Yes	No	
1.	Is there a completed floor plan?			
2.	Is there adequate space for maintenance needs? Front 36 in. (91.4 cm) minimum, rear 36 in. (91.4 cm) minimum are recommended clearances.			
3.	Is there adequate space for access to overhead cable trough(s)?			
4.	Is access to the site or computer room restricted?			
5.	Is the computer room structurally complete? Expected date of completion?			
6.	Is a raised floor installed and in good condition?			
7.	Are floor tiles in good condition and properly braced?			

Table 3-5 Site Inspection Checklist (Continued)

Please check either Yes or No. If No, include comment# or date				Comment or Date
8.	Is the raised floor adequate for equipment loading?			
9.	Are there channels, cutouts or overhead cable trough(s) for cable routing?			
10.	Is a telephone line available for servicing needs?			
11.	Are customer supplied peripheral cables and LAN cables available and of the proper type?			
12.	Is floor tile underside shiny or painted? If painted, judge the need for metallic particulate test.			
Power and lighting				
No.	Area or condition	Yes	No	
13.	Are lighting levels adequate for maintenance?			
14.	Does the DC input voltage correspond to equipment specifications?			
14A	Is dual source DC power used? If so, identify type(s) and evaluate grounding.			
15.	Is a NEBS compliant DC power source available?			
16.	Is there a dedicated branch circuit for equipment?			
17.	Are the input circuit breakers adequate for equipment loads?			
Safety				
No.	Area or condition	Yes	No	
18.	Is there an emergency power shut-off switch?			
19.	Is there a telephone available for emergency purposes?			
20.	Is there a fire protection system in the computer room?			
21.	Is antistatic flooring installed?			
22.	Are there any equipment servicing hazards (loose ground wires, poor lighting, and so on)?			
Cooling				
No.	Area or condition	Yes	No	
23.	Can cooling be maintained between 5°C and 40°C (up to 5,000 ft)? Derate 1°C/1,000 ft above 5,000 ft and up to 10,000 ft.			

Table 3-5 Site Inspection Checklist (Continued)

Please check either Yes or No. If No, include comment# or date				Comment or Date
24.	Can temperature changes be held to 10°C per hour with tape media? Can temperature changes be held to 20°C per hour without tape media?			
25.	Can humidity level be maintained at 40% to 55% (non condensing)?			
26.	Are air conditioning filters installed and clean?			
Storage				
No.	Area or condition	Yes	No	
27.	Are cabinets available for tape and disc media?			
28.	Is shelving available for documentation?			
Training				
No.	Area or Condition	Yes	No	
29.	Are personnel enrolled in the System Administrator's Course?			
30.	Is on-site training required?			

Delivery Survey

The delivery survey forms list delivery or installation requirements. If any of the items on the list apply, enter the appropriate information in the areas provided on the form.

Special instructions or recommendations should be entered on the special instructions or recommendations form. The following list gives examples of special instructions or issues:

- Packaging restrictions at the facility, such as size and weight limitations
- Special delivery procedures
- Special equipment required for installation, such as tracking or hoists
- What time the facility is available for installation (after the equipment is unloaded)
- Special security requirements applicable to the facility, such as security clearance

Figure 3-2 Delivery Survey (Part 1)



DELIVERY CHECKLIST	
DOCK DELIVERY	
Is dock large enough for a semitrailer? Yes _____ No _____	
Circle the location of the dock and give street name if different than address.	
<div style="display: flex; justify-content: space-between; align-items: center;">West<div style="text-align: center;"><p>North</p><p>South</p></div>East</div>	
STREET DELIVERY	
Circle the location of access door and list street name if different than address.	
<div style="display: flex; justify-content: space-between; align-items: center;">West<div style="text-align: center;"><p>North</p><p>South</p></div>East</div>	
List height _____ and width _____ of access door.	
List special permits (if required) for street delivery.	
Permit type:	Agency obtained from:
_____	_____
_____	_____

Figure 3-3 **Delivery Survey (Part 2)**

ELEVATOR

Fill in the following information if an elevator is required to move equipment.

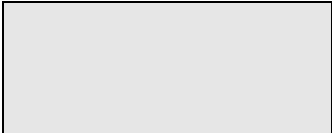
Capacity (lb or kg) _____

Depth _____

Height _____

Width _____

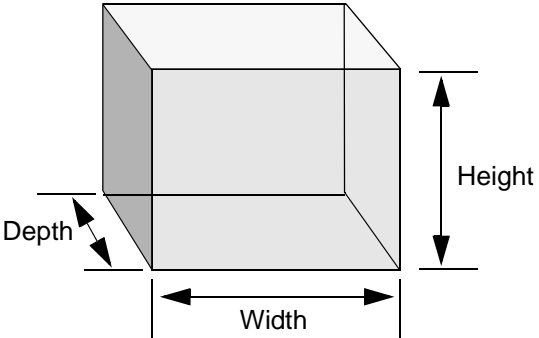

The diagram shows a 3D perspective of a rectangular box. Three dimension lines with arrows indicate the measurements: 'Depth' for the front-to-back length, 'Width' for the side-to-side length, and 'Height' for the vertical height.

STAIRS

Please list number of flights and stairway dimensions.

Number of flights _____ Number of flights _____

Width _____ Width _____

Width _____ Width _____

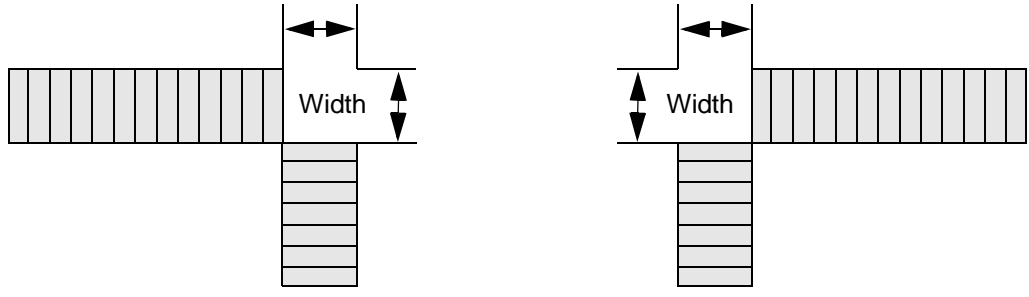

The diagrams show two types of stairs. The left diagram shows a flight of stairs going down from a landing, with a horizontal line representing the flight length and a vertical line representing the width. The right diagram shows a flight of stairs going up from a landing, with a horizontal line representing the flight length and a vertical line representing the width. Both diagrams have 'Width' labels with dimension lines.

Glossary

A-B

ASHRAE Standard 52-76 Industry standard for air filtration efficiency set forth by the American Society of Heating, Refrigerating, and Air-Conditioning Engineers, Inc.

ASL Above sea level.

board A printed circuit assembly (PCA). Also called a card or adapter.

Btu/h The abbreviation for British thermal units. The amount of heat required to raise one pound of water one degree Fahrenheit per hour, a common measure of heat transfer rate.

C

CompactPCI The newest specification for PCI-based industrial computers is called CompactPCI. It is electrically a superset of desktop PCI with a different physical form factor. See http://www.picmg.org/pdf/PICMG3_xIntro.pdf for details.

CFM The abbreviation for cubic feet per minute, commonly used to measure the rate of air flow in an air conditioning system.

Chilled water system A type of air conditioning system that has no refrigerant in the unit itself. The refrigerant is contained in a chiller, which is located remotely. The chiller cools water, which is piped to the air conditioner to cool the space.

D-K

Dehumidification The process of removing moisture from the air within a critical space.

Derate To lower the rated capability of an electrical or mechanical apparatus.

Downflow Refers to a type of air conditioning system that discharges air downward, directly beneath a raised floor, commonly found in computer rooms and modern office spaces.

EIA unit The Electronic Industries Association (EIA) defines this unit of measurement to be 1.75 inches in height. So then, 1U equals 1.75 inches (1U equals 44.45 mm).

Humidification The process of adding moisture to the air within a critical space.

Inrush current The peak current flowing into a power supply the instant power is applied. This peak is usually much higher than the typical input current due to the charging of the input filter capacitors. When switching power supplies are first turned on, they present high initial currents as a result of filter capacitor impedance. These large filter capacitors act like a short circuit, producing an immediate inrush surge current with a fast rise time. The peak inrush current can be several orders of magnitude greater than the supply's typical current.

KVA Abbreviation for kilovolt-amperes. (1,000 x volt-amperes).

L-N

Latent cooling capacity An air conditioning system's capability to remove heat from the air.

Maximum input current The operating current of the product equal to the maximum load divided by the minimum input voltage.

NEBS All electronic equipment has the potential to interfere with other electronic equipment. Interference can be caused by electromagnetic radiation, the grounding system, the electrical power connection, excessive heat, or blocking the natural airflow, and connecting wires or cables. The FCC (Federal Communications Commission) regulates a portion of this problem through Part 15 of their rules and regulations. Even more stringent than the FCC Part 15 requirements, Network Equipment Building Standards (NEBS) covers a large range of requirements including criteria for personnel safety, protection of property, and operational continuity. The documents cover both physical requirements including: Space Planning, Temperature, Humidity, Fire, Earthquake, Vibration, Transportation, Acoustical, Air Quality and Illumination; and electrical criteria including: Electrostatic Discharge (ESD), Electromagnetic Interference (EMI), Lightning and AC Power Fault, Steady State Power Induction, Corrosion, DC Potential Difference, Electrical Safety and Bonding and Grounding.

O-R

PCA Abbreviation for Printed Circuit Assembly also referred to as a Printed Circuit Board (PCB).

PCI Currently, the most popular local I/O bus, the Peripheral Component Interconnect (PCI) bus was developed by Intel and introduced in 1993.

PICMG A consortium of companies involved in utilizing PCI for embedded applications. The PCI Industrial Computer Manufacturers Group (PICMG) controls the PICMG specification.

S-T

Theoretical maximum power consumption

Represents the maximum wattage of a given configuration, assuming worst-case conditions (thermal tolerances, workloads, and so forth) on all system components. It is extremely unlikely that any customer will experience this level of power consumption.

Tonnage The unit of measure used in air conditioning to describe the heating or cooling capacity of a system. One ton of heat represents the amount of heat needed to melt one ton (2,000 lbs.) of ice in one hour. 12,000 Btu/hr equals one ton of heat.

Typical input current The operating current of the product measured using a typical load and target voltage.

Typical power consumption Represents the expected power consumption of a given configuration. The typical value is the approximate power consumption that a customer will most likely experience and can use for power budgeting purposes.

U-Z

Vapor seal A vapor seal is an essential part of preventing moisture infiltration into or migration out of a critical space, such as a data processing center or other room that contains sensitive electronic instrumentation. Essentially, a vapor seal is a barrier that prevents air, moisture, and contaminants from migrating through tiny cracks or pores in the walls, floor, and ceiling into the critical space. Vapor barriers may be created using plastic film, vapor-retardant paint, vinyl wall coverings and vinyl floor systems, in combination with careful sealing of all openings (doors and windows) into the room.

Watt A unit of electricity consumption representing the product of amperage and voltage. When the power requirement of a product is listed in watts, you can convert to amps by dividing the wattage by the voltage. (e.g., 1200 watts divided by 120 volts is 10 amps.)

A

air conditioning
 system recommendations, 29
air conditioning ducts, 30
air distribution system
 room space return air, 29

B

basic air conditioning equipment requirements, 28
basic air distribution systems, 29
branch circuit protection, 14

C

circuit breaker, 15
computer room safety
 fire protection, 21
cooling requirements, 28

D

data communications cables, 27
disconnect device, 14
ducts, air conditioning, 30

E

electrical and environmental guidelines
 air distribution system, 29
 computer equipment grounds, 24
 computer room safety
 fire protection, 21
 dust and pollution control, 30
 electrical conduit ground, 24
 grounding systems, 24
 lighting requirements, 22
 main building electrical ground, 24
 power distribution safety grounding, 24
 power panel grounds, 24
 power quality, 22
 sources of electrical disturbances, 23
 system installation guidelines, 26
electrical specifications, 14
environmental elements, 28
 acoustics, 32
 air conditioning equipment requirements, 28
 air conditioning recommendations, 29
 air distribution systems, 29
 computer room considerations, 28
 cooling requirements, 28
 dust and pollution control, 30
 electrostatic discharge
 prevention, 32
 humidity level, 30
 static protection measures, 32

F

facility characteristics, 33
facility guidelines
 characteristics, 33
 floor-plan grid, 36

 operational space requirements, 36
 typical raised floor site, 34
 windows, 35
fire protection, 21
floor loading
 raised floor, 33

G

grounding systems, 24
 electrical conduit ground, 24

H

humidity level, 30

K

Keystone system
 environmental elements, 28
 power system protection, 23
 temperature and humidity specifications, 16
 typical installation schedule, 38

M

main building electrical ground, 24

N

noise emission specifications, 19

P

power distribution hardware, 23
power distribution safety grounding, 24
power distribution system
 distribution hardware, 23
power quality, 22
power system protection, 23

R

raised floor
 ground system, illustrated, 26

S

sources of electrical disturbances, 23
space requirements, 36
 delivery space requirements, 36
system installation guidelines, 26
 data communications cables, 27
 wiring connections, 27

T

temperature and humidity specifications, 16
typical installation schedule, 38

W

wiring
 connections, 27

