

AD193A/AD194A PCI-X 4 Gigabit Fibre Channel and Gigabit Ethernet / Combination Card Overview

HP-UX Networking

HP 9000 and HP Integrity Systems



Manufacturing Part Number :

E1206

U.S.A.

© Copyright 2006 Hewlett-Packard Development Company L.P.

Legal Notices

The information in this document is subject to change without notice.

Hewlett-Packard makes no warranty of any kind with regard to this manual, including, but not limited to, the implied warranties of merchantability and fitness for a particular purpose. Hewlett-Packard shall not be held liable for errors contained herein or direct, indirect, special, incidental or consequential damages in connection with the furnishing, performance, or use of this material.

Warranty

A copy of the specific warranty terms applicable to your Hewlett-Packard product and replacement parts can be obtained from your local Sales and Service Office.

Restricted Rights Legend

Use, duplication or disclosure by the U.S. Government is subject to restrictions as set forth in subparagraph (c) (1) (ii) of the Rights in Technical Data and Computer Software clause at DFARS 252.227-7013 for DOD agencies, and subparagraphs (c) (1) and (c) (2) of the Commercial Computer Software Restricted Rights clause at FAR 52.227-19 for other agencies.

HEWLETT-PACKARD DEVELOPMENT COMPANY L.P.

20555 S.H. 249

Houston, Texas 77070

Use of this document and any supporting software media supplied for this pack is restricted to this product only. Additional copies of the programs may be made for security and back-up purposes only. Resale of the programs, in their present form or with alterations, is expressly prohibited.

Copyright Notice

Copyright © 1997-2006 Hewlett-Packard Development Company L.P. All rights reserved. Reproduction, adaptation, or translation of this document without prior written permission is prohibited, except as allowed under the copyright laws.

Trademark Notices

UNIX® is a registered trademark in the United States and other countries, licensed exclusively through The Open Group.

Itanium®, Itanium®2, Itanium Processor Family® (IPF), and Intel® are registered trademarks of Intel Corp.

HP Serviceguard® and Superdome® are registered trademarks of Hewlett-Packard Co.

Product Name Also Known As

The description of the AD193A product on the price list is “HP PCI-X 1p 4Gb FC and 1p 1000BT Adptr,” and the AD194A product on the price list is “HP PCI-X 2p 4Gb FC and 2p 1000BT Adptr.” For additional clarity and for use in some tasks, the name may appear slightly differently. Combined technologies are sometimes called “combination” or “multifunction” in an adapter or card. 1000Base-T is also commonly called 1000BT or Gigabit Ethernet.

Hardware and Software Installation Procedure

These instructions apply to AD193A/AD194A 4 Gigabit Fibre Channel and Gigabit Ethernet combination cards.

NOTE If your combination card is a built-in card or was factory installed (ordered on product option 0D1), the software bundles required for this card are already loaded onto your system's hard drive: you do not need to perform the following hardware and software installation steps, though you still need to configure the card's IP address, and optionally subnet mask and hostname. Skip to Step 3.

Adding in (installing) the card on HP-UX 11i v1 or 11i v2:

If adding the card yourself, you can get both the Gigabit Ethernet software driver and the Fibre Channel software driver from the June 2006 (or later) quarterly release software media.

You do not necessarily have to load the entire operating environment (OE) if you don't want to:

- You can either load the entire HP-UX 11i v1 or 11i v2 OE from the distribution media and you will automatically get the correct LAN and Fibre Channel software bundles.

or

- You can just select and load the software bundle **IEther-00** and **FibrChanl-01** required for this card.

These AD193A/AD194A combination cards can be added to your system or replaced without the need to shut down or reboot the system--a process called online addition and replacement (OLAR). The following instructions assume you are not performing online addition and replacement.

Step 1: Access the system card bay

- If the system is running, first, issue the `sync` command. Then shut down the system by executing: `shutdown -h`. Respond "y" to the continue to shutdown prompt.
- Wait for the system to shut down completely, and then power off the system by pressing the system off button. Ensure that the system is grounded.
- Open the system to gain access to the PCI backplane.
- Select an empty PCI or PCI-X slot and remove the slot cover. The card can operate in PCI as well as PCI-X mode. Some servers have "shared" slots. If you put this card in a shared slot that is shared with a *slower* card, both cards will then operate at the slower card's speed.

Step 2: Install the card

- Check the latest support matrix to see the systems that support this card, how many cards per system, and if any software updates are needed. The support matrix is available on the web at <http://docs.hp.com> under "Networking and Communications."
- Observe the antistatic precautions. HP recommends wearing ESD straps when installing the card.
- Record the serial number and MAC address located on the card for future reference. The MAC address labelled on the card refers to LAN port A. Add 0x1(Hex) to obtain the MAC address for LAN port B. For fibre channel, also record the card's Port and Node worldwide names (WWN). The WWN labelled on each card refers to WWN for FC port 1 (the left port). If it has 2 FC ports, add 0x2(Hex) to obtain the WWN for FC port 2 (the right port).
- Grasp the card by its edges or faceplate with both hands, insert the card into the slot, and firmly but gently press the card in until it is fully seated.

Step 3: Connect the card to the network

- Secure the card and reassemble the system.

Step 3: Connect the card to the network

- Attach the connector from a LAN cable to the card (Figure 1 on page 11). Do the same for the second port. For 1000Base-T, cabling must be Cat 5 UTP or better with RJ-45 connectors. For operating distances, refer to the “Cable Specifications” section of this document. Note: LAN A is the bottom RJ-45 connector.
- Attach the free end of the LAN cable to any unused port on the switch. The Base-T connections on the card operate at 10 or 100 Mbit/s in either full- or half-duplex modes and at 1000 Mbit/s only in full-duplex mode. Set the ports on the card and on your switch according to the following table.

Table 1 HP-UX 1000Base-T Supported Configurations

HP-UX 1000Base-T Port	Link Partner	Resulting Speed
AUTO	AUTO	Highest Common Speed (HP-UX supports 10/100/1000)
AUTO	1000 FD fixed/manual	1000 Mbit/s FD
10 HD	10 HD (for example, a 10Base-T Hub)	10 Mbit/s HD
10 FD	10 FD	10 Mbit/s FD
100 HD	100 HD	100 Mbit/s HD
100 FD	100 FD	100 Mbit/s FD

If you are using Jumbo Ethernet frames, ensure that:

- all end stations on a given LAN¹ have the same maximum transmission unit (MTU) setting.
- intermediate stations such as switch ports in your LAN have an MTU equal to or greater than the end station’s MTU.

Step 4: Connect the fibre channel devices

- Attach the LC connector from a fibre channel cable to the fibre channel connector on the card (Figure 1). For fibre channel, the cable must be 50 micron MMF. If the remote connection is type SC, you will need an LC-to-SC cable. Do the same for the other connector.
- Plug the other end of the fibre channel cable into the connector on your fibre channel switch or device.

Step 5: Prepare to install the software

- Ensure power cable is connected to system. Power up the system.
- Log in as root .
- Check that the /usr/bin, /usr/sbin, and /sbin directories are in your PATH using the command: echo \$PATH
- Check the HP-UX version by entering: `uname -r`

```
# uname -r
B.11.11
```

1. In the Jumbo Frames discussion, “LAN” means that the end stations do not have any routers or layer 3 switches in between them.

or

B.11.23

The version must be B.11.11 for 11i v1 or B.11.23 for 11i v2.

- Check the Release Notes for IETHER-00 and FibrChanl-01 to see if you need to install any appropriate patches for your system. Release Notes are available on the Web at <http://docs.hp.com> under Networking and Communications.

Step 6: Install the latest software.

- Load the software media into the appropriate drive.
- Run the `swinstall` program to install the software using the command: **swinstall**.
- Change the host name after “Source Host Name,” if necessary.
- Click the Source Depot Path to identify the registered depot for the appropriate source depot path and activate the OK button to return to the Software Selection Window.
- Highlight the 1000Base-T software **IETHER-00** (for cards such as AD193A/AD194A).
- Choose Mark for Install from the “Actions” menu to choose the product to be installed.
- Choose Install from the “Actions” menu to begin product installation and open the Install Analysis Window.
- Activate the OK button in the Install Analysis Window when the Status field displays a “Ready” message.
- Activate the YES button at the Confirmation Window to confirm that you want to install the software. `swinstall` loads the fileset, runs the control scripts for the filesets, and builds the kernel. This should take about 3 to 5 minutes. When the status field indicates Ready, click Done. A Note Window then opens. Click the OK button to reboot the system.
- If you are adding the fibre channel software bundle (**FibrChanl-01**) for 11i v1 or 11i v2, you can find the fibre channel software bundle on the June 2006 (or later) OE quarterly distribution media.

Step 7: Configure the card using SAM

- Log in as `root` and verify that the card and its hardware path are displayed by entering: **ioscan**.
- Run the System Administration Manager by entering `sam`.
- Double-click Networking and Communications.
- Double-click Network Interface Cards.
- Highlight the AD193A/AD194A combination Fibre Channel/Gigabit Ethernet card and choose Configure from the “Actions” menu.
- Fill in the form according to the instructions using the “Network Configuration Worksheet” in this document.
- Click the OK button to activate the card and then select `exit` from the “File” menu until you exit SAM.

Step 8: Verify the fibre channel installation

- To verify that the `fc` driver appears for each installed card, enter:
ioscan -fk

The `ioscan` output might look like the following:

Class	I	H/W	Path	Driver	S/W	State	H/W	Type	Description
<code>fc</code>	<code>4</code>	<code>1/0/8/1/0/4/0</code>	<code>fc0</code>	<code>CLAIMED</code>	<code>INTERFACE</code>	<code>HP AD194-60001</code>	<code>PCI/PCI-X</code>	<code>2-port 4Gb</code>	<code>FC/2-port 1000B-T Combo Adapter (FC Port 1)</code>

Step 9: Verify the LAN installation

```
fc 5 1/0/8/1/0/4/1 fcd CLAIMED INTERFACE HP AD194-60001 PCI/PCI-X 2-port 4Gb  
FC/2-port 1000B-T Combo Adapter (FC Port 2)
```

The last two digits of the hardware path (third column) reflect the path of each port. Both ports need to show as CLAIMED here.

- Verify that all devices you attached to the fibre channel card are listed in the ioscan output. For example, if you have a direct attach fibre channel device attached to the system, the ioscan output might look like:

```
8/12.8.0.255.0.1.0 sdisk CLAIMED DEVICE DGC C3400WDR5
```

The example above is the hardware path of LUN0 of a directly attached fibre channel mass storage device with loop ID of 1. If all attached devices are not listed, or for details on interpreting hardware paths, see the *HP Fibre Channel Mass Storage Adapters Support Guide*. HP fibre channel installation is verified if the ioscan output lists all mass storage devices attached to the card.

If the correct driver is installed, but the card does not show in the ioscan output, the driver is not recognizing the card. Make sure the card is seated and connectors are attached tightly, then if the problem persists, contact HP for assistance.

Step 9: Verify the LAN installation

- Verify that the LAN connector's Link LED is steadily on (this means the card and driver are installed successfully).
- Obtain the PPA number and the station address of each card by using the lanscan command. The MAC address labelled on each card refers to LAN port A. Add 0x1(Hex) to obtain the MAC address for LAN port B.
- To verify link-level connectivity with a remote system, enter:

```
$ linkloop -i PPA_number remote_station_address
```

Note: when you use linkloop, ensure that the remote system is on the same subnet and is an HP-UX-based system.

- To verify IP-level connectivity with a remote system, enter:

```
$ping Remote_IP_Address  
and  
netstat -in
```

When you use netstat -in, the output values IpKts and OpKts should be incrementing.

- Installation is complete when you have successfully run linkloop, ping and netstat. To configure remote systems, see the *Ethernet Support Guide* available on the web at <http://docs.hp.com>. Do this step only if remote systems have not been previously configured.
- Optionally, if you want to verify that the iether driver appears for each installed card, enter: `ioscan -fknclan`

The ioscan output for each port would look something like the following:

Class	I	H/W	Path	Driver	S/W	State	H/W	Type	Description
lan	6	1/0/2/1/0/6/0	iether	CLAIMED	INTERFACE	HP AD194-60001	PCI/PCI-X	2-port 4Gb	FC/2-port 1000B-T Combo Adapter

The last two digits of the hardware path (third column) reflect the path of each port -- in the sample output shown, the "0" indicates LAN A (as shown in Figure 1 on page 11). Both ports need to show as CLAIMED here.

Optional Step: Configure Jumbo Frames Size (Jumbo frames are supported only at 1000 Mbit/s)**Optional Step: Configure Jumbo Frames Size** (Jumbo frames are supported only at 1000 Mbit/s)

- Jumbo frames for the `iether` driver on HP-UX 11i v1 and HP-UX 11i v2 of September 2004 (or later) have an MTU in the range of 1501 to 9000 bytes.

If you are using Jumbo Ethernet frames, ensure that:

- all end stations on a given LAN¹ have the same maximum transmission unit (MTU) setting;
- intermediate stations such as switch ports in your LAN have an MTU equal to or greater than the end station's MTU.

- Obtain the PPA number of the card by entering `lanscan`.
- Choose one of two configuration methods that will permanently save your configuration.
 - use the GUI-based system admin manager (SAM).
To use SAM, type `sam` at the HP-UX system prompt; then double-click Networking and Communications, and then Advanced Configuration--see *Ethernet Support Guide* for details, and then do the steps for verifying the MTU size;

or

edit the following configuration file using an editor such as "vi":

```
/etc/rc.config.d/hpietherconf.
```

Set the `mtusize` by editing:

```
HP_iether_MTU[i]=mtusize, and insert the proper interface name:
```

```
HP_iether_MTU[i]=HP_iether_INTERFACE_NAME. When the system reboots, the interface will be configured for jumbo frame operation.
```

- Verify MTU change by entering `netstat -rn`. If MTU has not changed, enter the following commands:

```
$ifconfig lan PPA_number unplumb
$ifconfig lan PPA_number ip_address netmask netmask up
```

- To check (or verify) the current Ethernet frame size, enter:

```
$lanadmin -m PPA_number
```

An alternative way to temporarily configure jumbo frame size is to enter:

```
lanadmin -M mtu_size PPA_number.
```

Using `lanadmin` is temporary because it will not preserve your settings across reboots.

The `PPA_number` is the one we obtained from the output of `lanscan`. For using Jumbo Frames with the `iether` Gigabit Ethernet driver on HP-UX 11i v1 or HP-UX 11i v2 of September 2004 (or later), set the `mtu_size` to a number in the range of 1501 to 9000 bytes.

For Further Information

For further information on the Gigabit Ethernet and Fibre Channel as implemented in this card, please refer to <http://docs.hp.com> and then look under Networking and Communications. This card's information is primarily located under the subsection called "Combination Cards."

1. In the Jumbo Frames discussion, "LAN" means that the end stations do not have any routers or layer 3 switches in between them.

Hardware and Software Installation Procedure
For Further Information

Maintenance and troubleshooting information about the iether Gigabit Ethernet driver used in this product is located in the *Ethernet Support Guide*. There is maintenance and troubleshooting information about the fcd Fibre Channel driver used in this product in the *HP Fibre Channel Mass Storage Adapters Support Guide*. There is also a *Support Matrix* for Gigabit Ethernet and a separate one for Fibre Channel. The fcd driver is the same one used in the AB378A/AB379A Fibre Channel product and has the same features as the driver described in that product's documentation.

Network Configuration Worksheet

Fill out one worksheet for the networking data of each LAN port on the combination card you are installing.

Table 2 Network Configuration Worksheet

Data Type	Required/ Optional	Default	How to Configure (see Note 1)	Example	Your System
Internet Address	Required	0.0.0.0	SAM or ifconfig or edit /etc/rc.config.d/ netconf	196.6.20.2	
Subnet mask	Required if using subnetting	Subnet mask not used	SAM or ifconfig or edit /etc/rc.config.d/ netconf	255.255.248.0	
Station address	Built-in but can be optionally changed	As shown on card	SAM or edit /etc/rc.config.d/ hpietherconf or temporarily: lanadmin -A	0x0060b0c4012f	
Host name alias for this network interface (card)	Required if the system is connected to more than 1 network	None	SAM or edit /etc/hosts	host1	
Link configuration	Required	Autonegotiating	SAM or temporarily: lanadmin -X	lanadmin -X auto_on ppa# (if already turned off)	
Link speed/duplex mode	Required	Autonegotiating	Hub or switch (see Note 2) SAM or temporarily: lanadmin -X	lanadmin -X 100fd ppa#	
MTU (Maximum Transmission Unit): Jumbo Frames	Optional	1500 bytes	SAM or edit /etc/rc.config.d/ hpietherconf or temporarily: lanadmin -M	lanadmin -M 9000 ppa# (see Note 3 below)	
Receive flow control	Optional	On	SAM or edit /etc/rc.config.d/ hpietherconf or temporarily: lanadmin -X	lanadmin -X fctrl off	

Note 1: To configure values permanently, edit the configuration files using SAM or an editor such as “vi”. Using lanadmin will not preserve your settings across reboots.

Note 2: The speed configuration of the card can be 10, 100, or 1000 Mbit/s and is determined by the speed setting of the hub or switch port to which the card is connected. The card automatically senses this speed. The Base-T card only runs at one speed at a time. To verify the speed selection, run `lanadmin -x ppa#`.

Note 3: The valid MTU size for normal frames using the iether driver on HP-UX 11i v1 or v2 is 1500 bytes. For Jumbo Frames, the valid MTU size for iether on HP-UX 11i v1 or HP-UX 11i v2 is a number in the range of 1501 to 9000 bytes.

Cable Specifications

Operating Distance for 1000Base-T (Copper UTP): Up to 100 meters — Cat 5 and Cat 5E

Operating distances for fibre channel using multi-mode fiber optic cable are as follows:

Description (Fibre Channel)	Rate	Operating Distance
50/125 micron MMF	4 Gbits/s	150 meters (492 ft)
50/125 micron MMF	2 Gbits/s	300 meters (984 ft)
50 micron MMF	1 Gbits/s	500 meters (1640 ft)

Available HP Fiber Optic Cables:

LC-LC	
C7524A	Fibre Channel Cable 2m LC duplex 50/125 M/M Optical
C7525A	Fibre Channel Cable 16m LC duplex 50/125 M/M Optical
C7526A	Fibre Channel Cable 50m LC duplex 50/125 M/M Optical
LC-SC	
C7529A	Fibre Channel Cable 2m LC-SC duplex 50/125 M/M Optical
C7530A	Fibre Channel Cable 16m LC-SC duplex 50/125 M/M Optical
Adapter/Extenders	
C7534A	Fibre Channel Adapter SC Form Factor
Adapter Kit	
C7540A	Fibre Optic Adapter Kit - Optical: Includes 2m LC/SC Cable and F/F extender

Figure 1 AD194A PCI-X 2-Port 4 Gb FC/ 2-Port 1000B-T Combination Card

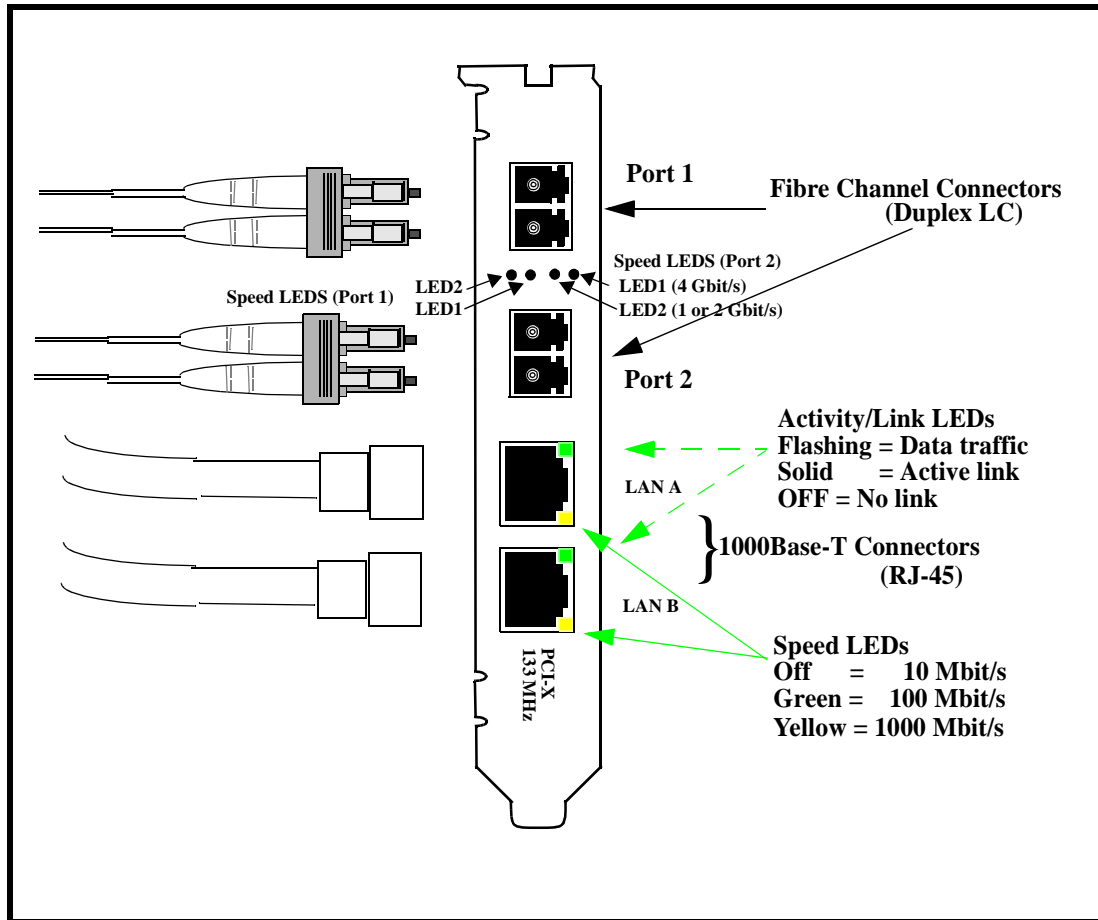

The following table shows the meaning of the different LED patterns:

Table 3 LED Patterns

Card State	LED 1 Yellow (4Gbit/s)	LED 2 Amber/Green (2/1Gbit/s)	Meaning
Power Off	Off	Off	Card doesn't have power
Power On	On	Amber On	Card powered on and not initialized
Power On	1 Flash/s	Amber 1 Flash/s	After firmware initialization, Awaiting Link Up. All flashing at same time.

Table 3 LED Patterns

Card State	LED 1 Yellow (4Gbit/s)	LED 2 Amber/Green (2/1Gbit/s)	Meaning
Firmware Fault	2 Flash/s	Amber 2 Flash/s	All 3 LEDs flash in continuous sequence
1Gbps Link UP/ACT	Off	Amber On 5 Flash/s	Online I/O Activity
2Gbps Link UP/ACT	Off	Green On 5 Flash/s	Online I/O Activity
4Gbps Link UP/ACT	On 5 Flash/s	Off	Online I/O Activity

Features

The AD193A/AD194A PCI-X Combination cards have the following features:

- **PCI-X 133 MHz** capable card. It can operate at 32-bit or 64-bit compatible modes and is supported in the following frequencies: PCI 66, PCI-X 66, and PCI-X 133. Best performance is achieved by putting the card in a “**dual-rope**” PCI-X 133 slot. To identify which slots are the dual rope slots in a particular system, please refer to the hardware users’ guide for each system. The AD193A/AD194A card is *not* supported in PCI 33 bus mode. It operates in **3.3V slots only**. Reduction of Hazardous Substances (RoHS) compliant.
- Supports HP-UX 11i v2 (64 bit) or 11i v1 on HP 9000 (PA-RISC-based) and HP-UX 11i v2 (64 bit) only on HP Integrity (Itanium® or Itanium®2-based) platforms.
- The Gigabit Ethernet ports support use of **Jumbo Frames**.
- Supports HP **Serviceguard** and Auto-Port Aggregation (**APA**) for high availability.
- The Gigabit Ethernet port supports virtual LANs (**VLANs**). This feature is described in *Using HP-UX VLANs* on <http://docs.hp.com>
- Supports PCI-X online addition/replacement (**OLA/R**) on specified systems. For instructions on how to perform online addition and replacement (OLAR) for PA-RISC-based systems running HP-UX 11i v1, see *Configuring HP-UX For Peripherals*. For instructions on performing OL* for Itanium-based systems and PA-RISC systems running HP-UX 11i v2 of September 2004 or later, refer to the *Interface Card OL* Support Guide*.
- Supports configuration through **SAM** or command line.
- vPars support with vPars 4.02 and 4.03 on supported HP Integrity and HP 9000 (PA-RISC-based) systems. Enables creation of additional partitions per server.
- Supports 16k LUNs on the Fibre Channel ports.
- Supports boot/dump on Fibre Channel ports and LAN Boot on Gigabit Ethernet ports.
- Online/Offline Diagnostics.
- Ignite-UX support.
- Supports readout of Vital Product Data (VPD) for Fibre Channel. To read the Fibre Channel VPD, use: `fcmsutil devicefilename vpd`.
- Firmware for the Fibre Channel ports -- version is 4.00.70 as of the publication of this document. The FC EFI driver firmware version is 1.05. For GigE, the bootcode is version 2.16; EFI is v3.0.0.3 or later. To check for updates of these, see the section “For Further Information” in this document.
- Fibre channel transfer rates of 4Gbit/s, 2Gbit/s, and 1Gbit/s. The Fibre Channel speed LED colors indicate the following speeds:
 - Yellow (4G)
 - Green (2G)
 - Amber (1G)
- Auto speed sensing on the Fibre Channel ports.
- Supports Fibre Channel protocols SCSI-FCP-2 and FC-Tape.
- Supports the following Fibre Channel topologies:
 - FC-SW
 - FC-AL-2

Features

- FC-FLA
- FC-PLDA
- FC-PI
- Supports PCI-X error handling. This feature provides a system with improved fault-tolerance. PCI-X Error Handling allows an HP-UX system to avoid a Machine Check Abort (MCA) or a High Priority MachineCheck (HPMC), if a PCI-X error occurs (for example, a parity error).

A Physical, Environmental and Regulatory Information

This appendix contains regulatory statements for the United States, Canada, Australia/New Zealand, Japan, and the European community.

Card Physical and Environmental Specifications

Following are the product physical and environmental specifications of the AD193A/AD194A PCI-X 2-Port 4Gigabit Fibre Channel and 2-Port Gigabit Ethernet Combination Card.

Physical Specifications

Form Factor	PCI half-card form-factor PCI-X (rev 2.3)
PCI support	64-bit 3.3V only 133Mhz
Width	10.8 cm (4.25 in)
Length	16.9 cm (6.6 in)
Thickness	2.0 cm (0.7 in)
Weight	0.105 kg (0.2 lb) kg

Environmental

Temperature

Degrees F = (1.8 x Degrees C) + 32

Operating Temperature Range (Degrees Celsius)	+5° C to 40° C
Recommended Operating Temperature Range (Degrees Celsius)	+10° C to 30° C
Non-operating/ storage Temperature Range (Degrees Celsius)	-40° C to 70° C
Temperature Shock Immunity - Max Rate of Change	20 C/hr
Non-operating/storage Humidity Range in %RH	90
Recommended Operating Humidity Range @ 22 Degrees Celsius in %RH	40 to 60
Heat Dissipation (in Watts)	17
Maximum kV (if less than 15 kV) with no loss of function	8

Physical, Environmental and Regulatory Information
FCC Statement (For U.S.A.)

Maximum kV (if less than 25 kV) with no component damage	25
Operating Altitude	3,000 meters (9900) ft
Non-operating Altitude	4,500 meters (14850 ft)

Electromagnetic Compatibility

This document contains regulatory statements for the United States and the European community.

FCC Statement (For U.S.A.)

Federal Communications Commission Radio Frequency Interference Statement

WARNING This device complies with Part 15 of the FCC rules. Operation is subject to the following two conditions:
(1) This device may not cause harmful interference and
(2) this device must accept any interference received, including interference that might cause undesired operation.

This equipment has been tested and found to comply with the limits for a Class A digital device, pursuant to Part 15 of the FCC rules. These limits are designed to provide reasonable protection against harmful interference when the equipment is operated in a commercial environment. This equipment generates, uses and can radiate radio frequency energy, and, if not installed and used in accordance with the instruction manual, may cause harmful interference to radio communications.

Operation of this equipment in a residential area is likely to cause interference, in which case the user at his own expense will be required to take whatever measures may be required to correct the interference.

Hewlett-Packard's system certification tests were conducted with HP-supported peripheral devices and cables, such as those received with your system. Changes or modifications to this equipment not expressly approved by Hewlett-Packard could void the user's authority to operate the equipment.

Canada

Warning: This Class A digital apparatus meets all requirements of the Canadian Interference-Causing Equipment Regulations.
Cet appareil numérique de la classe A respecte toutes les exigences du règlement sur le matériel brouilleur du Canada.

EMI Statement (European Community)

NOTE This is a Class A product. In a domestic environment, this product may cause radio interference, in which case you may be required to take adequate measures.

Laser Safety Statements

Laser Safety Statements - U.S. FDA/CDRH - Optical (laser) Transceiver

CAUTION The optical transceiver provided on the network interface card contains a laser system and is classified as a “Class-I Laser Product” under a U.S. Department of Health and Human Services (DHHS) Radiation Performance standard according to the Radiation Control for Health and Safety Act of 1968. The Class I label and compliance statement are located on the optical transceiver.

To ensure proper use of this product, please read this instruction manual carefully and retain for future reference. Should the unit ever require maintenance, contact an authorized service location.

CAUTION Use of controls, adjustments or the performance procedures other than those specified herein may result in hazardous radiation exposure. To prevent direct exposure to laser beam, do not try to open the enclosure.

Laser Safety - European Union - Optical Transceiver Only



CAUTION The optical transceiver provided on the network interface card contains a laser system and is classified as a “Class 1 Laser Product” per EN 60825-1, Safety of Laser products. Class 1 laser products are considered safe and do not pose a biological hazard if used within the data sheet limits and instructions.

To ensure proper use of this product, please read this instruction manual carefully and retain for future reference. Should the unit ever require maintenance, contact an authorized service location.

CAUTION Use of controls, adjustments or the performance procedures other than those specified herein may result in hazardous radiation exposure. To prevent direct exposure to laser beam, do not try to open the enclosure.

Physical, Environmental and Regulatory Information
Laser Safety Statements

There are no user serviceable parts nor any maintenance required for the optical transceiver. All adjustments are made at the factory before shipment to customers. Tampering with or any attempt to modify the optical transceiver will result in voided product warranty. It may also result in improper operation of the network card circuitry and possible overstress of the laser source. Device degradation or product failure may result.

	DECLARATION OF CONFORMITY according to ISO/IEC 17050-1 and EN 17050-1
	DoC #: CPTOJ-0611-A
Supplier's Name:	Hewlett-Packard Company
Supplier's Address:	10500 Ridgeview Court Cupertino, CA. 95014
declares, that the product	
Product Name and Model:	HBA, PCI-X 1-P 4Gb FC and 1-P 1000B-T, AD193A HBA, PCI-X 2-P 4Gb FC and 2-P 1000B-T, AD194A
Regulatory Model Number:¹⁾	CPTOJ0611
Product Options:	All
conforms to the following Product Specifications and Regulations:	
EMC: Class A	
CISPR 24:1997 + A1:2001 + A2:2002	
CISPR 24:1997 + A1:2001 + A2:2002	
FCC CFR 47 Part 15	
AS/NZS CISPR 22:2004EN 55022:1994 + A1:1995 + A2:1997	
EN 55022:1998 + A1:2000 + A2:2003	
EN 55024:1998 + A1:2001 + A2:2003	
Safety:	
EN 60950-1:2001	
CNS 14336 2004	
EN 60825-1:1994 + A1:2002 + A2:2001	
AS/NZS 60950.1:2003	
This device complies with part 15 of the FCC Rules. Operation is subject to the following two conditions: (1) This device may not cause harmful interference, and (2) this device must accept any interference received, including interference that may cause undesired operation.	
The product herewith complies with the requirements of the Low Voltage Directive 2006/95/EC, the EMC Directive 2004/108/EC and carries the CE-marking accordingly.	
Additional Information:	
1) This product is assigned a Regulatory Model Number which stays with the regulatory aspects of the design. The Regulatory Model Number is the main product identifier in the regulatory documentation and test reports, this number should not be confused with the marketing name or the product numbers.	
Cupertino CA March 26 2007	 Tom Le, Hardware Engineer
Local contact for regulatory topics only:	
EMEA: Hewlett-Packard GmbH, HQ TRE, Herrenberger Strasse 140, 71034 Boeblingen, Germany	www.hp.com/go/certificates
U.S.: Hewlett-Packard, 3000 Hanover St., Palo Alto 94304, U.S.A. 650-857-1501	